

# Turning Center

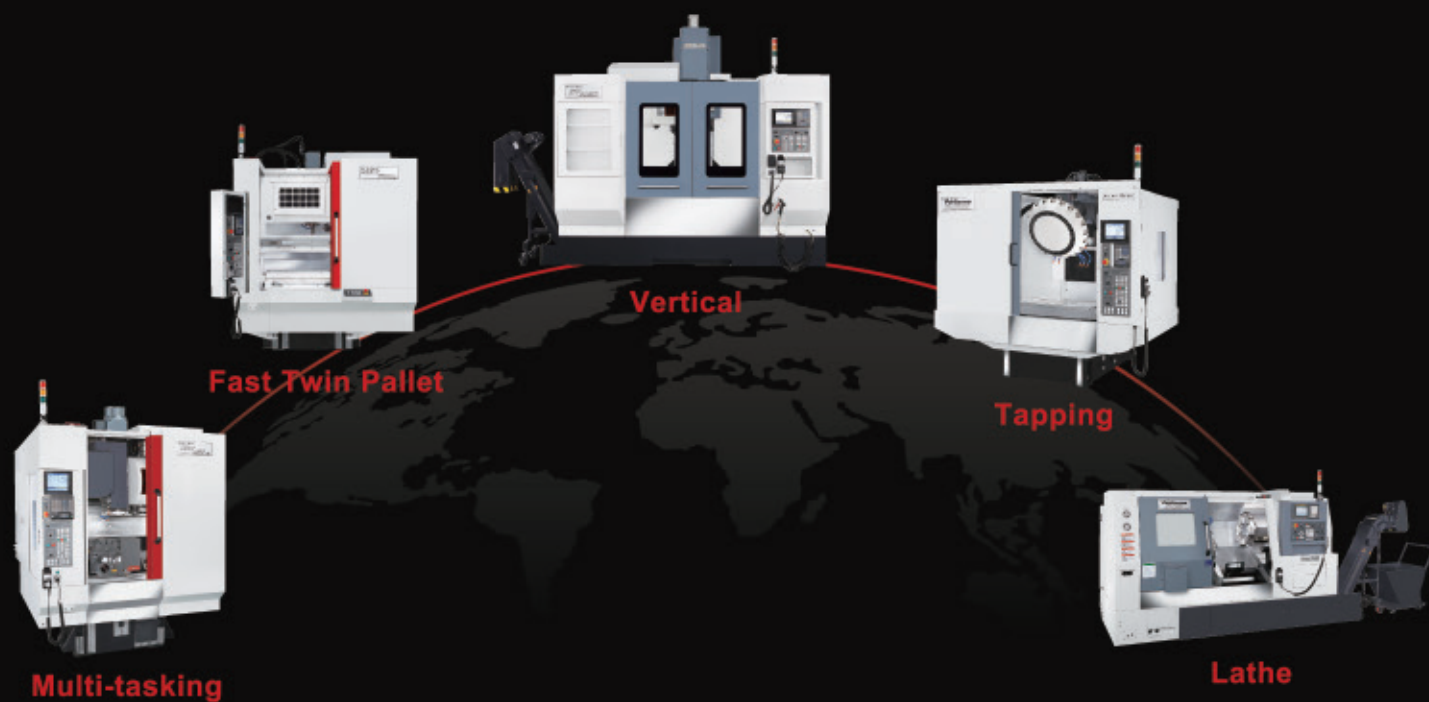



► **Headquarter**

255 CAPITOL ST., LIVERMORE, CA 94551, USA

TEL:+1 925 443 1200

FAX:+1 925 443 1290

► **Production Line**

**1st Factory**

No.5 Jingle E Rd., Nantun Dist., Taichung City  
40852, Taiwan

**2nd Factory**

No.35, 36th Road, Industrial Park Taichung City  
40768, Taiwan

TEL:+886 4 2355 2495

FAX:+886 4 2355 2496



Designed by 箭頭 影畫行銷 2019.02

# Turning Center



Decide with Confidence





# General

Akira Seiki devotes to build up turning center with stability and friendly operation.

From chuck size 6" to 18" that we provide a wide range of production.

## SL25

2 Axis Turning Model  
SL25  
3 Axis Turning Model  
SL25MC



## SL40

2 Axis Turning Model  
SL40, SL40L  
3 Axis Turning Model  
SL40MC, SL40LMC



## SL15/SL20

2 Axis Turning Model  
SL15, SL20



## SL35

2 Axis Turning Model  
SL35, SL35L  
3 Axis Turning Model  
SL35MC, SL35LMC



## GT12

2 Axis Turning Model  
GT-12



## SL30

2 Axis Turning Model  
SL30, SL30L  
3 Axis Turning Model  
SL30MC, SL30LMC



## SL30SMC

Sub Spindle





# Structure

Akira Seiki Turning Center casting are steady to perform outstandingly dynamic accuracy and vibration absorption while rapid cutting.

## MEEHANITE High Quality Casting Iron

Assures permanent rigidity and accuracy for each AKIRA SEIKI machine casting frame by the authorized Meehanite foundries



### Stable Head Cartridge

Feature in high rigidity and acceleration efficiency. Fully support from stable head stock and drive by high horsepower output covering spindle speed, AKIRA-SEIKI SL model can operated heavy loads with high quality and polished surface finishing in higher speed new cutting technology way.

### Head Stock Thermal Control

The spindle headstock is of one-piece casting reinforced with thermal to prevent heat extension and ensure the life time of spindle bearing.

### Two-stepped Rigid Base Support

To enforce the steady rigidity while fast feeding cut, Turning Center base designed in dual level of Z axial guide ways. This increased contact face by both lower and upper guide way obtain more cutting rigidity than conventional only-one contact face.

AKIRA-SEIKI SL models with fully two-stepped guide ways with fully balance contact support. (Available for SL30(L)(MC)/ SL35(L)(MC) / SL40(L)(MC) only)

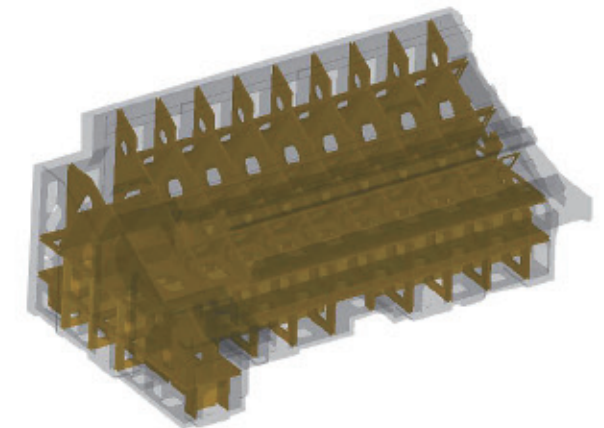
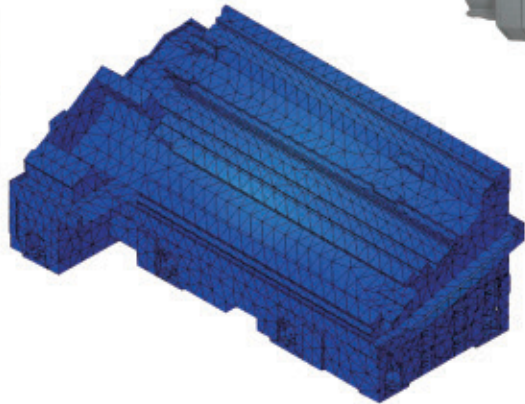
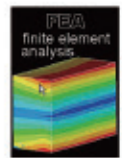
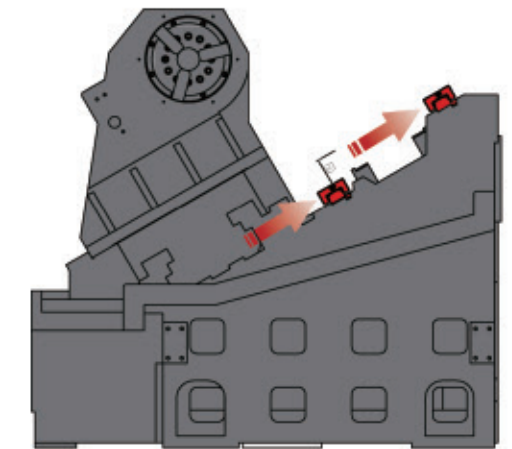
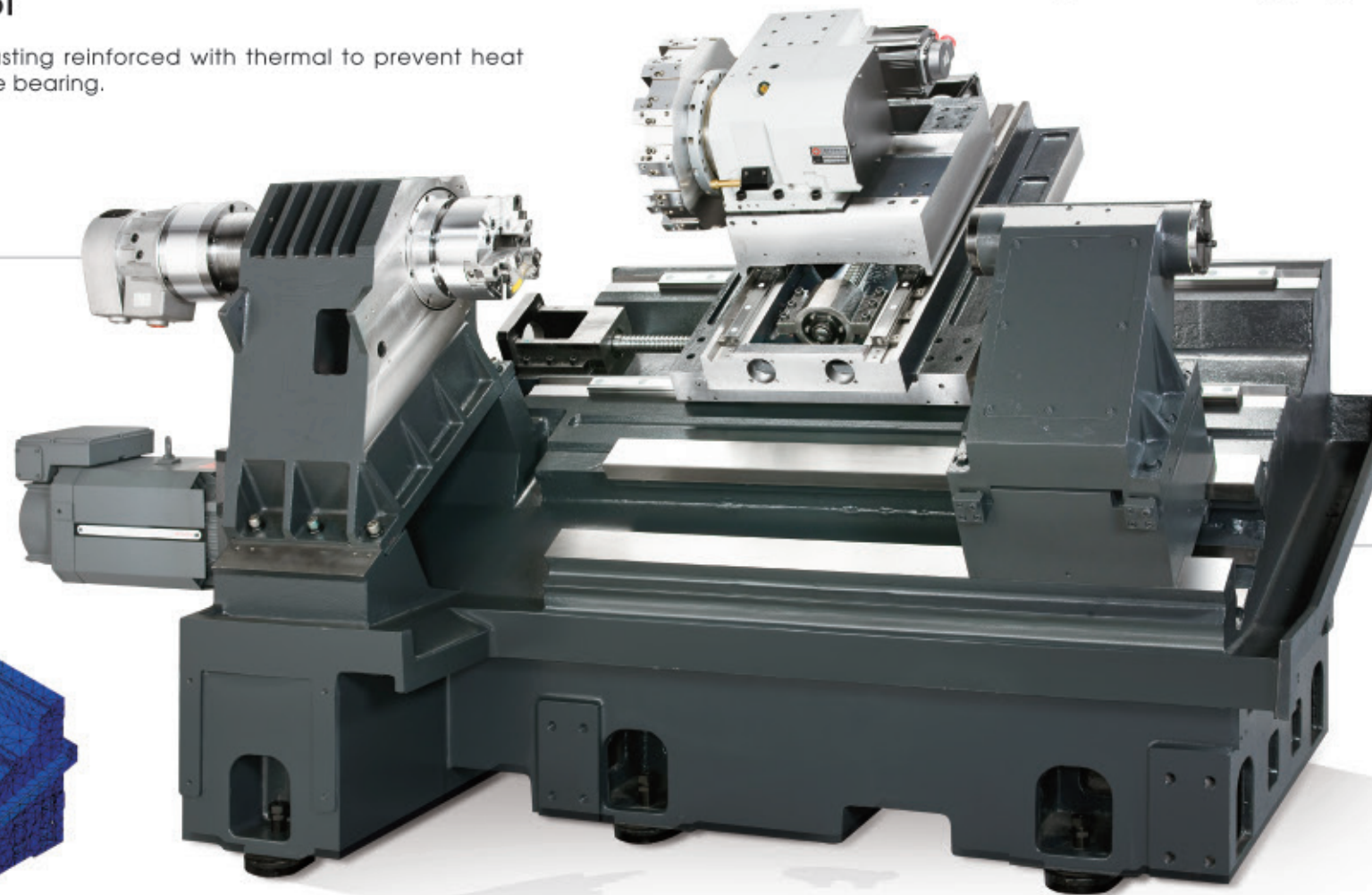

### Scientific Technology Support

Physical rigidity are ensured for all AKIRA-SEIKI Turning Center in the primary design progress by advanced digital assay tool. All structural frames apply COSMOS system for analysis to optimize rigid mechanism foundation.

Digital FEA (Finite Element Analysis) scientifically demonstrates rigid structure and approves excellent dynamic accuracy and vibration absorb by advanced digital assay tool.

### Reinforced Frame Construction

AKIRA-SEIKI Turning Center casting are steady as rock to perform excellent dynamic accuracy and vibration absorption while rapid cutting.

The internal ribs of each key casting elements like base, column, head-cartridge and saddles are enforced for deformation-resistant and anti-damp vibration.



**AKIRA-SEIKI Turning Center Patent**  
Easier alignment of spindle center when machine gets crashed and spindle displacement.



### Guide Pin

For aligning the casting properly with the work.

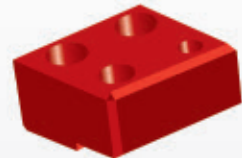

### Adjusting Block

Readjust the center easier by guide pin.

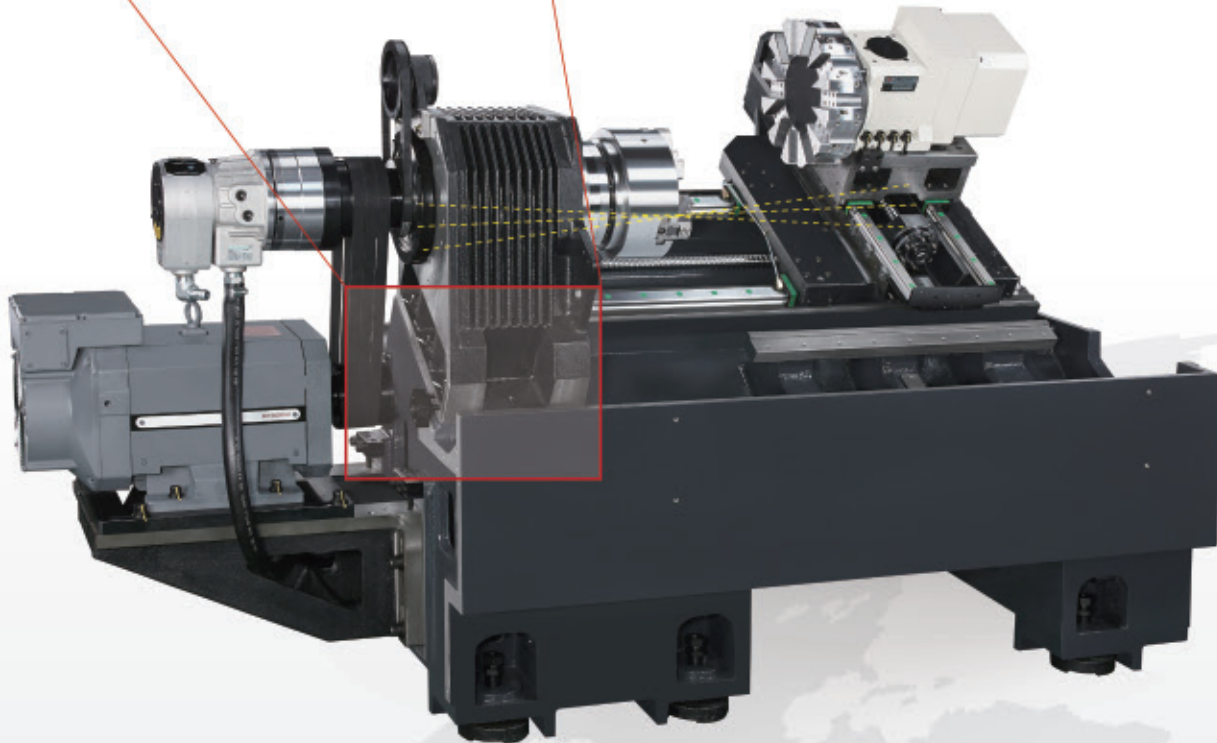
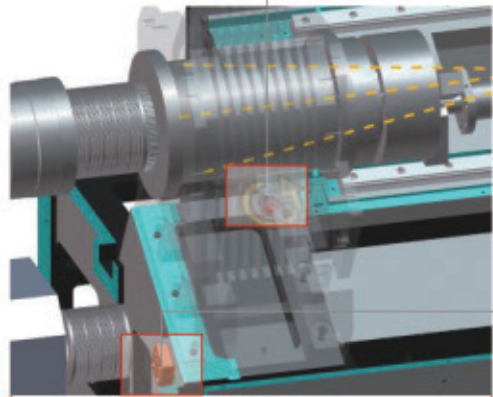

## Roundness (Turning)

- Machine Type : **SL20**
- Material : **S45C Steel (JIS), CK45(DIN), 1045 (ASTM)**
- Hardness: HRC60
- Tool : CBN160C
- Spindle Speed : 500 rpm
- Machining Diameter :  $\varnothing$  65 mm
- Feed Rate: 0.05 mm/rev
- Roundness : **Ra 0.6  $\mu$ m**

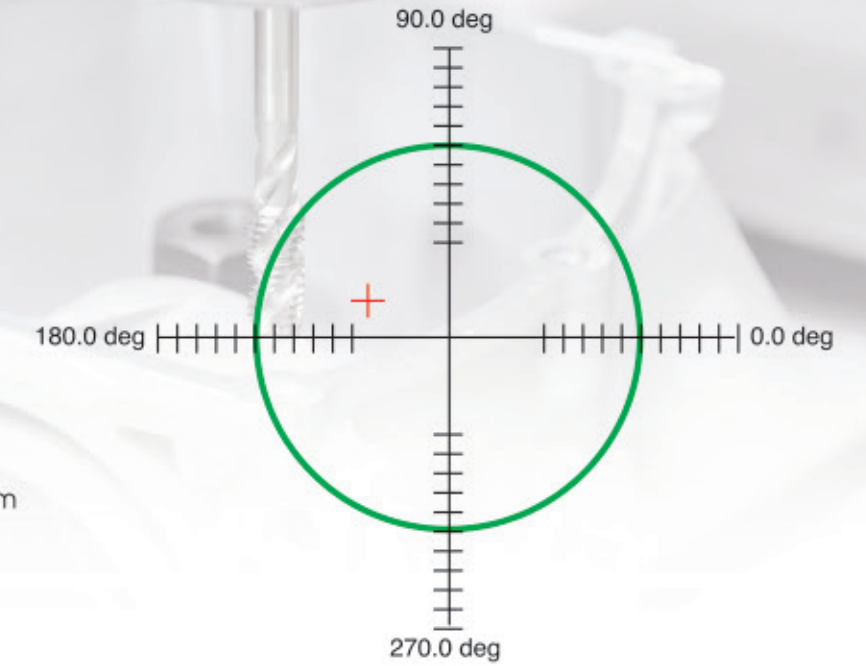

## Surface Roughness Rz 0.97

(Under customer customized application)

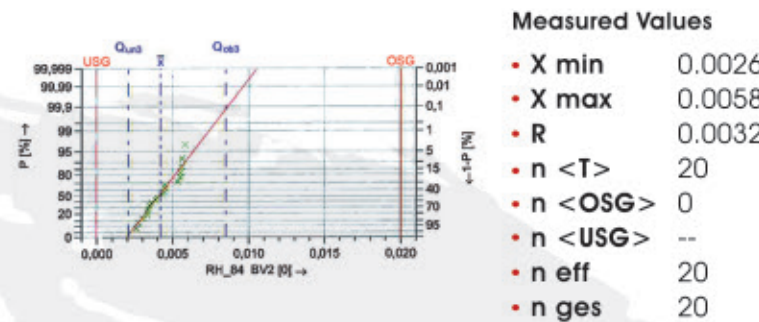
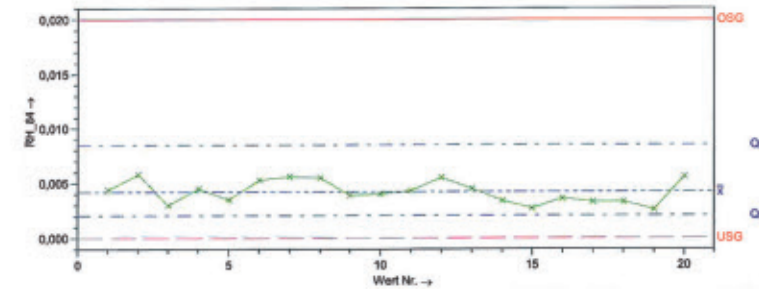

### Measured Values

- X min 0.0026
- X max 0.0058
- R 0.0032
- n <T> 20
- n <OSG> 0
- n <USG> --
- n eff 20
- n ges 20



The cutting test results indicated in this catalog are provided as examples  
The measured results may not be obtained due to differences in cutting conditions and environmental conditions



# Spindle Feature

World class servo spindle drive and motor to seize the essential technology to increase low speed torque and constant high horsepower output covering wide spindle speed.

## GT12

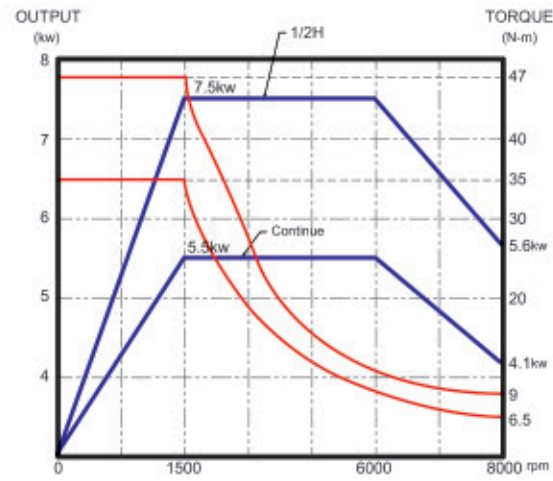

## SL15

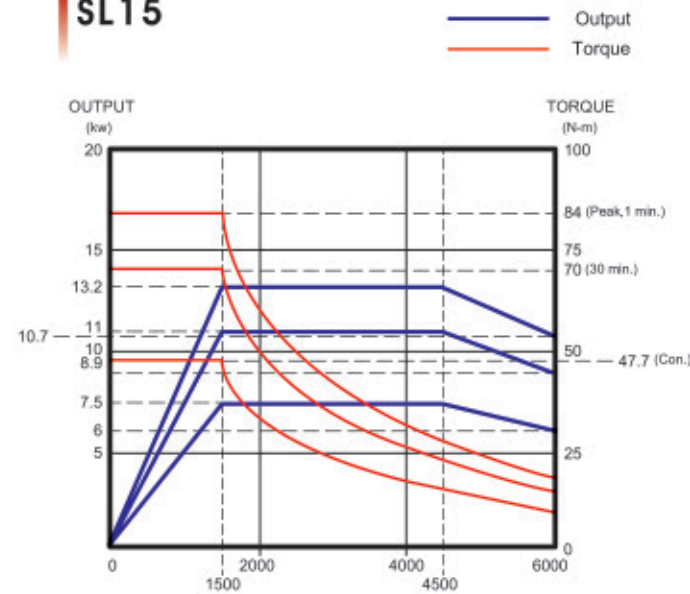

## SL40/SL40L/SL40MC/SL40LMC With ZF Gear Box

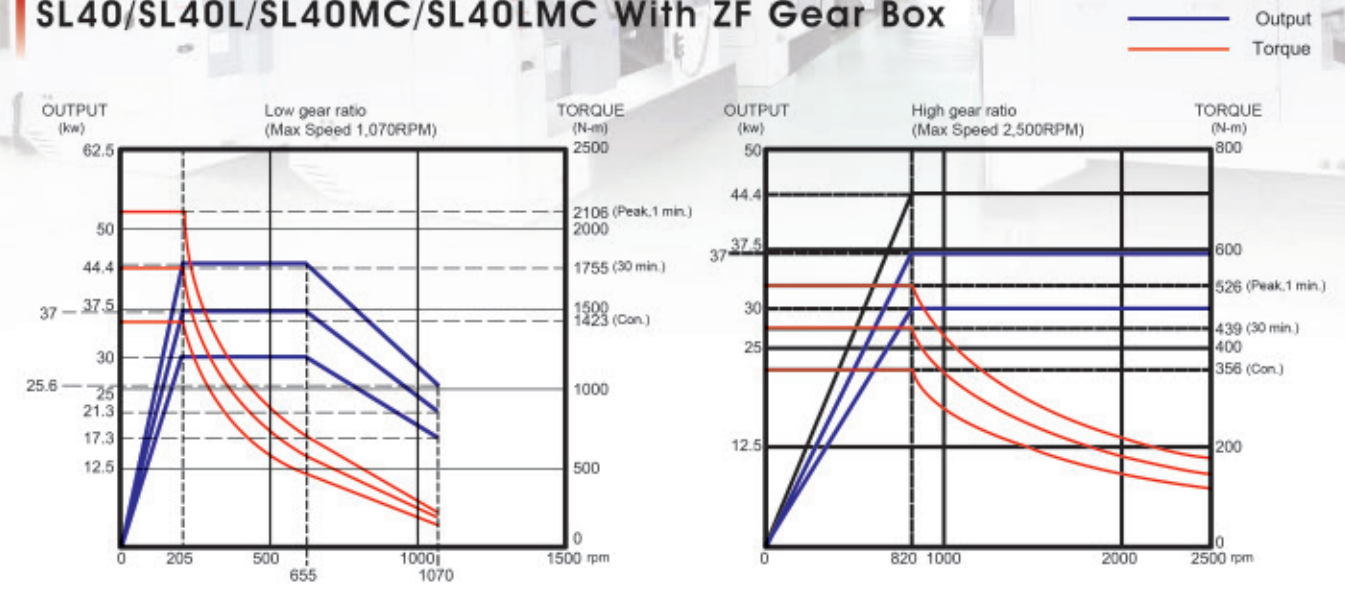

## SL20

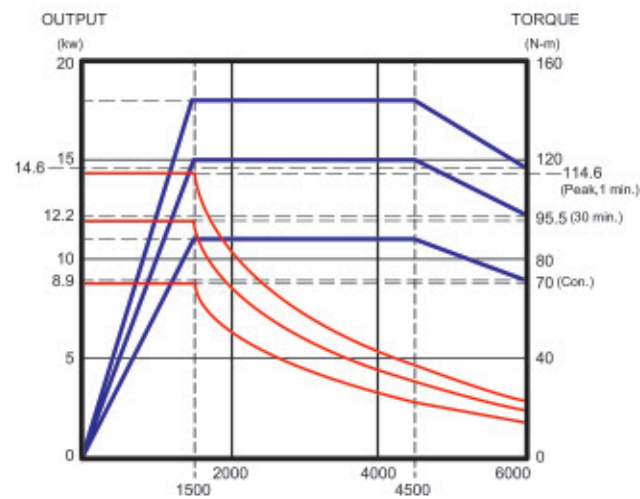

## SL25/SL25MC

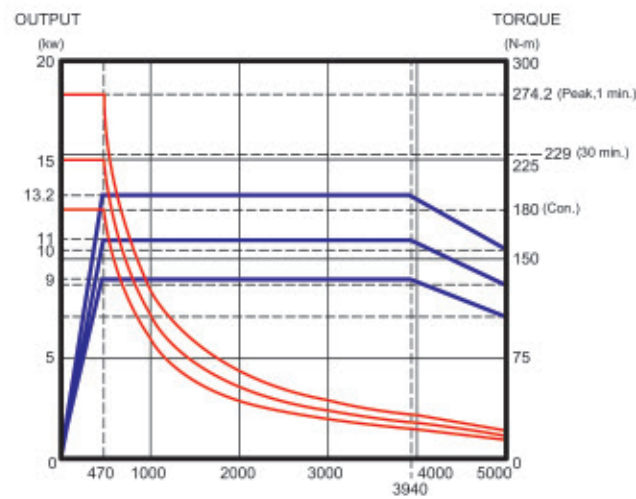

## SL30/SL30L/SL30MC/SL30LMC

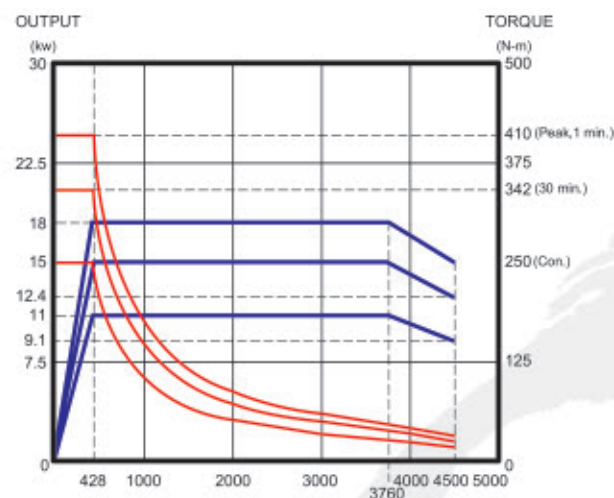

## SL35/SL35L/SL35MC/SL35LMC

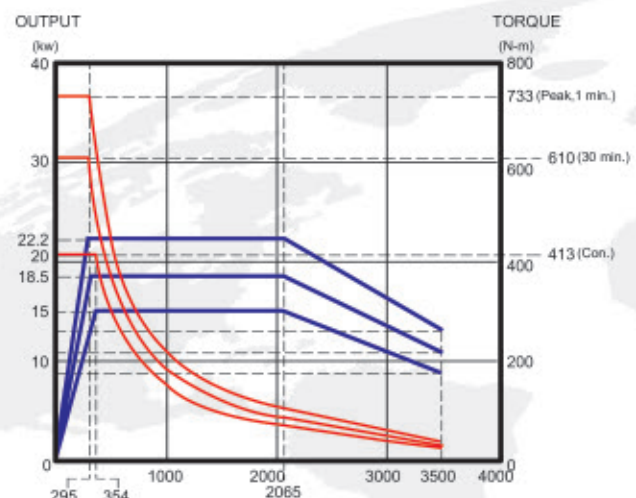

## Turning Capacity

material: S45C (JIS)

### Heavy-duty Cutting (O.D)

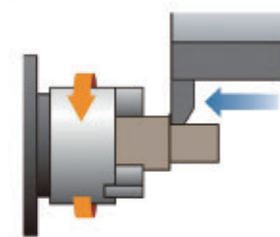

	SL30	SL35
Depth of cut	7 mm	7 mm
Spindle speed	750 min <sup>-1</sup>	800 min <sup>-1</sup>
Feed rate	0.3 mm/rev	0.4 mm/rev
Cutting speed	200 m/min	216 m/min
<b>Material removal rate</b>	<b>485 mL/min</b>	<b>676 mL/min</b>

### Throw-away Drill

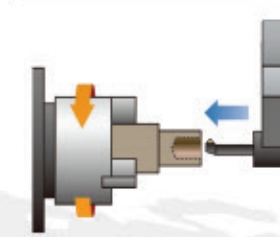

	SL30	SL35
Depth of cut	∅ 56 mm	∅ 56 mm
Spindle speed	1023 min <sup>-1</sup>	1136 min <sup>-1</sup>
Feed rate	0.2 mm/rev	0.25 mm/rev
Cutting speed	90 m/min	100 m/min
<b>Material removal rate</b>	<b>450 mL/min</b>	<b>625 mL/min</b>

### O.D Grooving

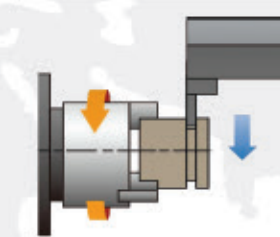

	SL30	SL35
Groove width	∅ 8 mm	∅ 10.5 mm
Spindle speed	286 min <sup>-1</sup>	341 min <sup>-1</sup>
Feed rate	0.4 mm/rev	0.5 mm/rev
Cutting speed	90 m/min	120 m/min

The cutting test results indicated in this catalog are provided as examples. The measured results may not be obtained due to differences in cutting conditions and environmental conditions.



# AKIRA M<sub>i</sub>845 Control

AKIRA M<sub>i</sub>845 coordinate the CNC digital and world leader drives system. High-resolution servo stabilize precise axis positioning for high complex and accuracy jobs.

● : Standard ▲ : Option X : N/A	GT12/SL15/SL20	SL25(MC)/SL30(L)(MC) SL35(L)(MC)/SL40(L)(MC)
<b>CPU Processor / Base Specification</b>		
RISC CPU Processor	RISC 64 bit	RISC 64 bit
Memory capacity (1m=0.4KB)	500KB (1,280)	● 500KB ▲ 2MB (1,280)
Number of programs stored	1000 programs	1000 programs
Extended workpiece coordinate system selection (sets)	48 sets	48 sets
Workpiece coordinate system preset (G92.1)	●	●
Max. sets of variable	● 600 sets	● 700 sets
Max. number tool offset sets	● 99 sets	● 99 sets
<b>Display Unit Related Specification</b>		
8.4 inch color TFT LCD	●	X
10.4 inch color TFT LCD	X	●
<b>Language Display &amp; Graphic Check Related Function</b>		
Display language selection	17	17
2D Graphic check and trace	●	●
<b>Operation Related Functions</b>		
Front SD card mode	●	●
USB memory I/F	●	●
Ethernet Interface	●	●
NC-Explorer	●	●
Operation & G-Code guidance	●	●
Alarm & Parameter guidance	●	●
NC data backup (Automatic & Manual)	●	●
Manual speed command (Program check by Handle)	●	●
<b>Simple Programming Function</b>		
NAVI-LATHE	●	●
<b>Programming Support Related Function</b>		
Helical interpolation (G 17 ~G 19+G02/G03)	●	●
Cylindrical interpolation (G07.1/G107)	●	●
Polar coordinate interpolation (G 12.1 /G 13.1)	●	●
Milling interpolation	X	●
Coner Chamfering / Coner Rounding /Geometric	●	●
Linear angle command	●	●
Multi-start thread cutting	●	●
Finished shape chamfering (G71 / G72)	●	●
Pecking tapping cycle / deep hole tapping cycle	●	●
Simple handle tool length measurement	●	●

\*Please contact with your local distributor for the further information, those specs. and value based on AKIRA M<sub>i</sub>845 Controller.

## Faster, Easier Program Edition Progressive Programming Guidance

### Conversational Programming

The **friendly interactive message** by machining icons to guide users for programming before practical operation. **Various processing models** can be selected to satisfy **basic turning and turn-milling complex application**.



#### ▲ Turn Icon

Turn Menu **7** main option  
Total **20** processing models

Turn Hole | Drilling | Threading  
Grooving | Copy Cut | Trapezoid

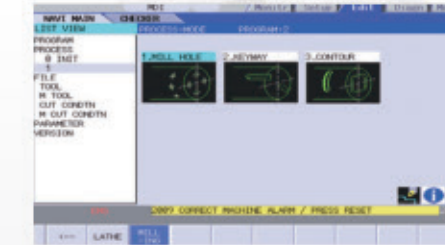

#### ▲ Mill Icon

Turn Menu **3** main option  
Total **10** processing models

Milling Hole | Keyway Cut | Contour Cut

### Magicpro-NAVI LATHE on PC and Lathe

The easy programming system can be **applied in users' own PC operation**. To save efficiency without disturbing machine processing, **the program can be edited and simulated on PC** before practical cut. Optimum application for training purpose!

Items such as machining programs, tool files and cutting-condition files can be sharing between the NAVI programs on CNC Lathe and PC.

(by Compact flash card / USB memory)



### Graphic Check

The operator can check the completed NC programs by previewing simulation through the tool path graphic checker function.

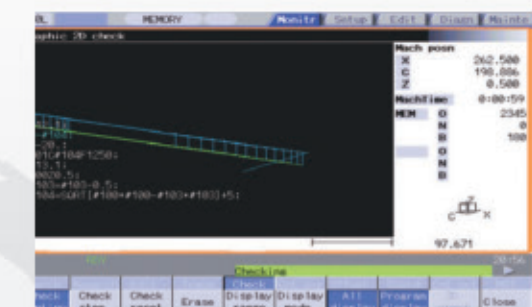



# Dimension of Workpiece

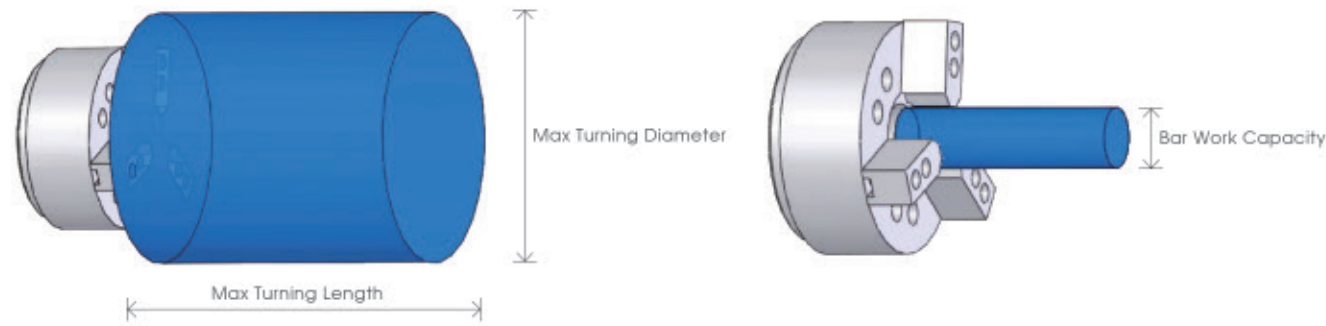
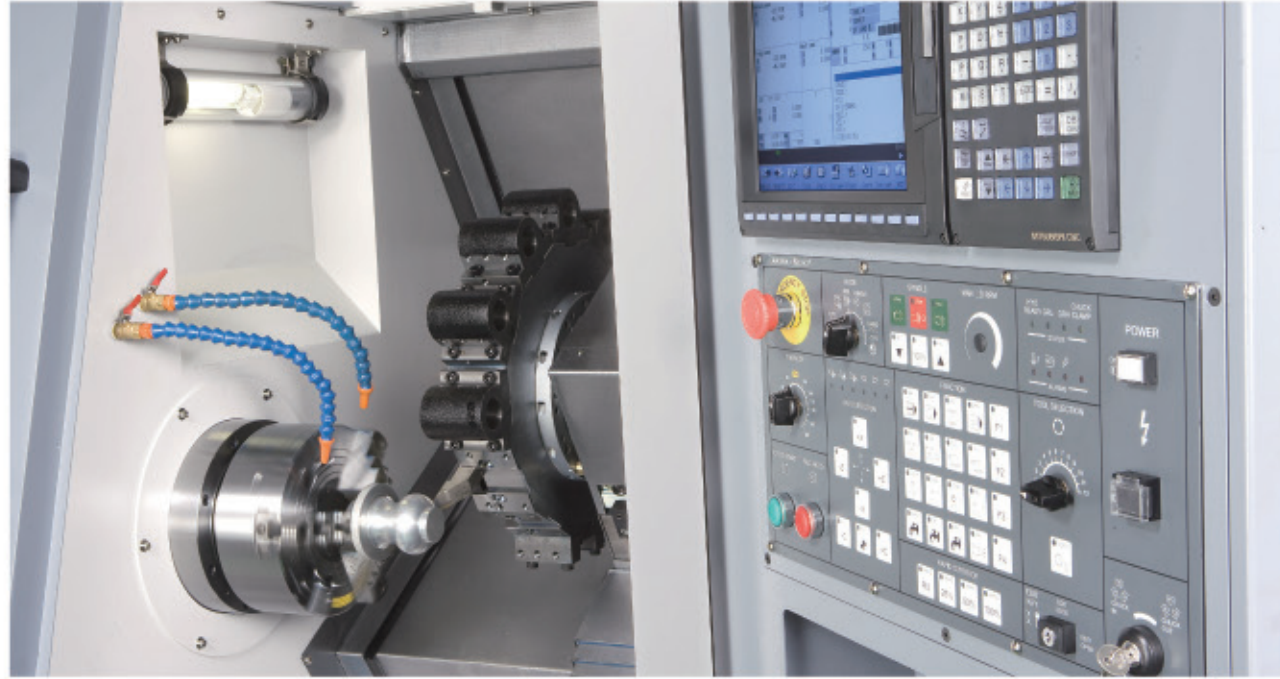

	GT12	SL15	SL20	SL25	SL30 / SL30L	SL35 / SL35L	SL40 / SL40L
				SL25MC	SL30MC / SL30LMC	SL35MC / SL35LMC	SL40MC / SL40LMC
Swing Over Bed	400 / 15.7	450 / 15.7	450 / 15.7	530 / 20.9	600 / 23.6	650 / 25.6	750 / 29.5
Max. Over Cross Slide	-	280 / 11	280 / 11	350 / 13.8	400 / 15.7	450 / 17.7	550 / 21.7
Draw Tube Bore	42 / 1.7	42 / 1.7	45 / 1.8	52 / 2.0	65 / 2.6	78 / 2.6	103 / 4.1
Max. Cutting Diameter	-	280 / 11	280 / 11	350 / 13.8	400 / 15.7	400 / 15.7	550 / 21.7
				280 / 11	330 / 13	360 / 14.2	380 / 15
Max. Cutting Length	200 / 7.9	200 / 7.9	330 / 13	400 / 15.7	600 (23.6) / 1000 (39.4)	600 (23.6) / 1000 (39.4)	950 (37.4) / 1500 (59)
				380 / 15	540 (21.26) / 940 (37)	540 (21.26) / 940 (37)	830 (32.7) / 1380 (54.3)

mm / Inch

# Tooling System

**10 / 12T**  
For SL 2-axis

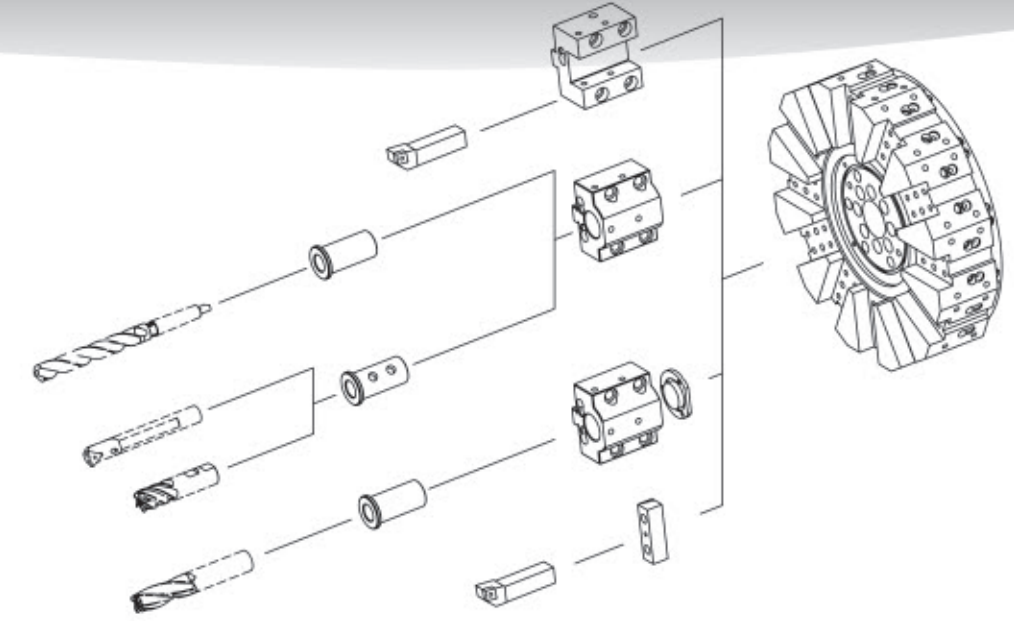

**12T**  
Power Tool Turret for SL-MC (OPT)

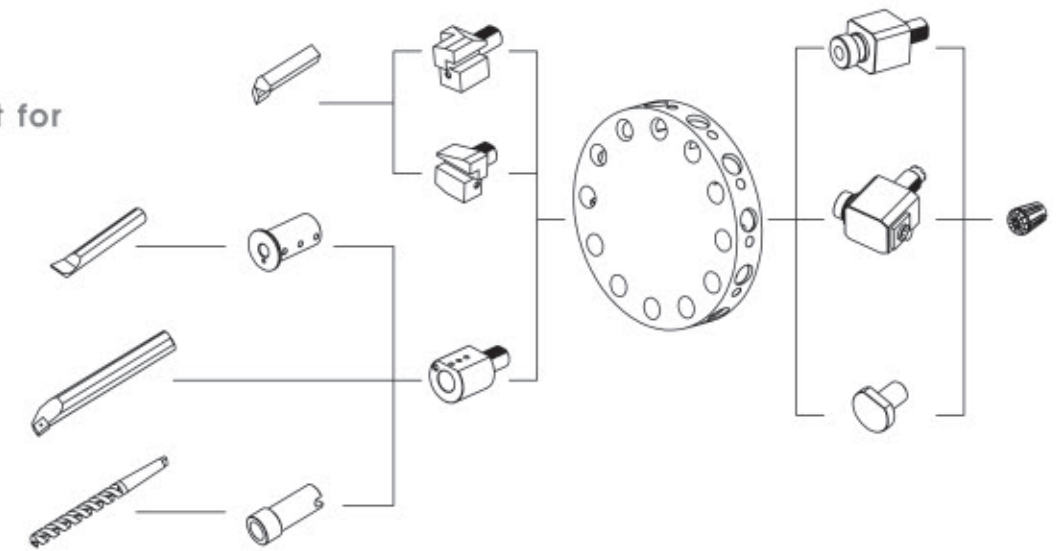

Model and Turret	GT12	SL15 SL20	SL25	SL30 SL30L SL35 SL35L	SL40 SL40L	SL25MC	SL30MC SL35MC SL40MC SL30LMC SL35LMC SL40LMC
	Gang Tool Seat	Polygon 10T	Polygon 12T	Polygon 12T	Polygon 12T	Power Turret 12T VDI30 Axial	Power Turret 12T VDI30 Axial
Tool Holder	Spec x Qty						
ID tool holder	Ø16x6	Ø25x4	Ø32x4	Ø40x4	Ø50x4	N/A	N/A
Boring bar sleeve	Ø 6/8/10/12/16 x1	Ø 8/10/12/16/20 x1	Ø 8/10/12/16/20/25 x1	Ø 8/10/12/16/20/25/32 x1	Ø 8/10/12/16/20/25/32/40 x1	N/A	N/A
O.D tool holder	□ 20x2	□ 20x7	□ 20x8	□ 25x8	□ 32x8	N/A	N/A
Face tool holder	N/A	x1	x1	x1	x1	N/A	N/A
Axial VDI tool holder	N/A	N/A	N/A	N/A	N/A	OPT	OPT
Radial VDI tool holder	N/A	N/A	N/A	N/A	N/A	OPT	OPT



# Accessories

**Automation bar handling & Ergonomics for parts handling**  
designed for increasing liner productivity that easily set-up and short cycle time for bar loading. Accept various bar shape also for square and hexagonal materials.

## Part Catcher (OPT)

No need to interrupt the operation and open door to collect the complete parts manually, the parts catcher automatically swings into the position to catch up the completed parts and gather then in a bin.

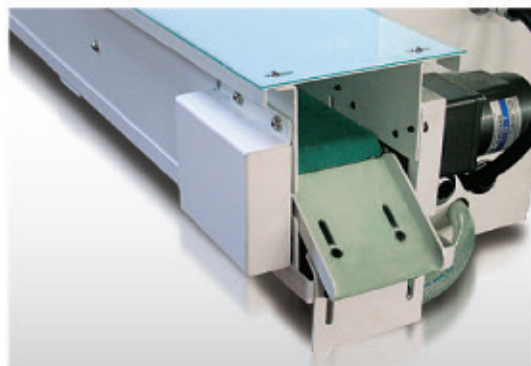

## Part Conveyor (OPT)

A recommended device to combined the application of parts feeder automation, the parts conveyor is driven by initial command to carry the parts by safe distance from each. All these complete parts are delivered into another finished part storage made by users.

## Bar Feeder (OPT)

Easy set-up and short cycle time for bar loading. Accept various bar shape also for square and hexagonal materials.



**Convenience built-in software to easy the setting and satisfy variable bar turning application.**

## Cut Off

First cut off for datum

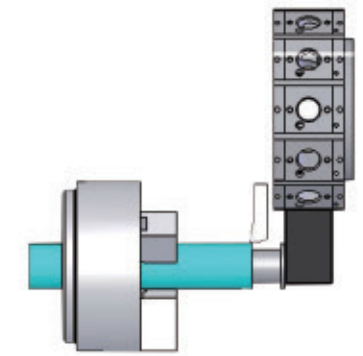

## Safe Bar Forward

Regular bar length feeding, the turret stays in set safe distance (from 0.1~1 mm by operator's setting) from part datum to bar stopper and then move in Z axial direction together with bar feeding. Instead of conventional bar-feeding stops while part pushing turret, Akira Seiki smart software to serve safe buffer distance saves turret from crashing by bar length error setting.

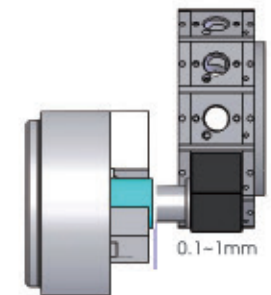

## Multi Section Bar Feeding

Unlike conventional all processing strokes feeding at once, Akira Seiki SL smart software allow the bar feed by multi length setting. This reserves best cutting rigidity for long part material in multi sectional turning process.

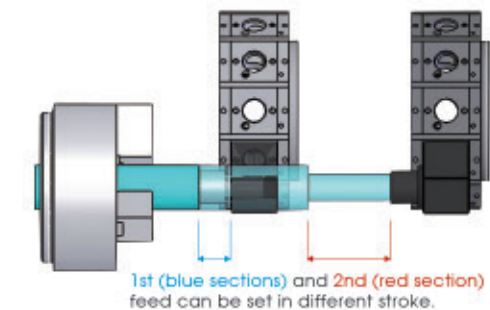

## Polygon-Shaped Bar Feeding

Only by parameter setting, the spindle orientation by jogging is available minimum 15 degree for each indexing as each single-step indexing. This spindle jogging orientation provides ensured secure clamping for polygon shape bars.

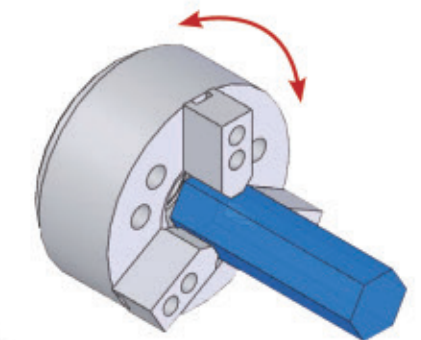



# Working Range & Measurement

## Working Envelope

### 10T / 12T Turret for 2 axis model

mm / inch

	GT12	SL15	SL20	SL25	SL30	SL35	SL40
					SL30L	SL35L	SL40L
A	220 / 6.8	220 / 6.8	350 / 13.8	435 / 17.1	610 / 24 1010 / 39.7	630 / 24.8 1025 / 40.3	975 / 28.3 1525 / 60
B	-	80 / 3.1	80 / 3.1	80 / 3.1	90 / 3.5	90 / 3.5	135 / 5.3
C	-	272 / 10.7	272 / 10.7	316 / 12.4	400 / 15.7	410 / 16.1	520 / 20.5
D	-	150 / 5.9	150 / 5.9	195 / 7.7	220 / 8.7	235 / 9.3	285 / 11.2
E	-	15 / 0.6	15 / 0.6	15 / 0.6	20 / 0.8	20 / 0.8	25 / 1
F	-	-	80 / 3.12	100 / 3.9	100 / 3.9	100 / 3.9	100 / 3.9
G	42 / 1.7	42 / 1.7	45 / 1.7	52 / 2	65 / 2.6	78 / 3.1	117.5 / 4.6
H	-	-	330 / 13	467 / 18.4	627 / 24.6 1027 / 40.4	850 / 33.4 1245 / 48.7	1023 / 40.2 1573 / 61.8
I	184.5 / 7.3	194 / 7.7	179 / 7	182.5 / 7.19	183 / 7.2	186 / 7.32	239 / 9.4
J	-	30 / 1.1	32 / 1.3	30 / 1.1	40 / 1.57	40 / 1.57	45 / 1.77

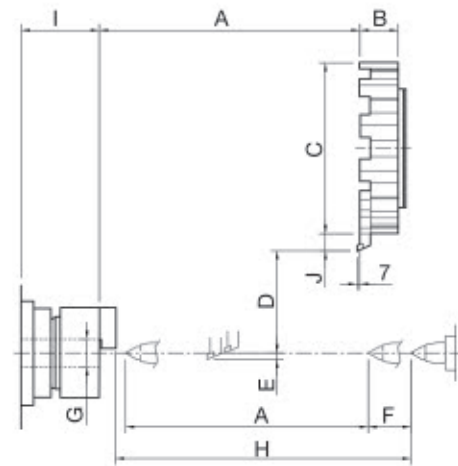

## Tooling Interference

### Polygon 10T/12T turret for 2 axis model

mm / inch

	GT12	SL15 SL20	SL25	SL30 SL30L	SL35 SL35L	SL40 SL40L
H	-	15 / 0.59	15 / 0.59	20 / 0.8	20 / 0.8	25 / 0.98
I	-	150 / 5.9	195 / 7.7	220 / 8.7	235 / 9.3	285 / 11.2
J	-	166 / 6.5	188 / 7.4	240 / 9.4	245 / 9.6	305 / 12
K	-	102 / 4.02	95 / 3.7	122 / 4.8	145 / 5.7	99 / 3.9
L	-	245 / 9.6	299.5 / 11.7	345 / 13.5	349 / 13.4	385 / 15.16
M	-	272 / 10.7	316 / 12.4	400 / 15.7	410 / 16.1	520 / 20.5

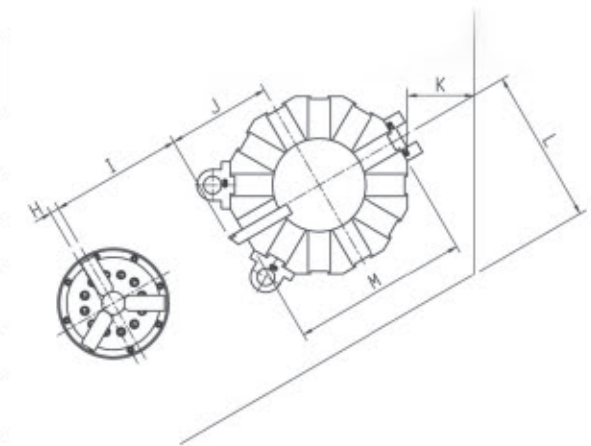

### Axial type 12T VDI Turret for SL-MC

mm / inch

	SL25MC	SL30MC	SL35MC	SL40MC
		SL30LMC	SL35LMC	SL40LMC
A	435 / 17.1	600 / 23.6 1000 / 39.9	600 / 23.6 1000 / 39.9	900 / 35.4 1450 / 57.1
B	56 / 2.2	76 / 2.99	76 / 2.99	110 / 4.3
C	440 / 17.3	440 / 17.3	440 / 17.3	380 / 14.9
D	195 / 7.7	220 / 8.66	235 / 9.25	285 / 11.2
E	-	-	-	-
F	100 / 3.9	100 / 3.9	100 / 3.9	100 / 3.9
G	52 / 2	65 / 3	78 / 3.1	105 / 4.1
H	480 / 18.9	691.4 / 27.2 1091.4 / 42.9	800 / 31.4 1206 / 47.2	948 / 37.3 1498 / 59
I	181 / 7.1	183 / 6.8	186 / 7.32	239 / 9.4

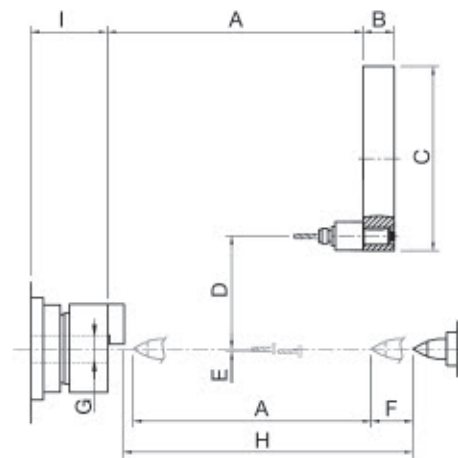

### Axial type 12T VDI Turret for SL-MC

mm / inch

	SL25MC	SL30MC SL30LMC	SL35MC SL35LMC	SL40MC SL40LMC
A	5 / 0.2	5 / 0.2	5 / 0.2	25 / 1
B	195 / 7.67	220 / 8.7	235 / 9.25	285 / 11.2
C	185 / 7.28	185 / 7.28	185 / 7.28	200 / 7.9
D	80 / 3.15	141 / 5.5	173 / 6.8	88 / 3.46
E	299.5 / 11.7	345 / 13.5	349 / 13.7	385 / 15.1
F	114 / 4.4	159 / 6.2	164 / 6.45	123 / 4.8
G	370 / 14.57	370 / 14.57	370 / 14.57	400 / 15.7

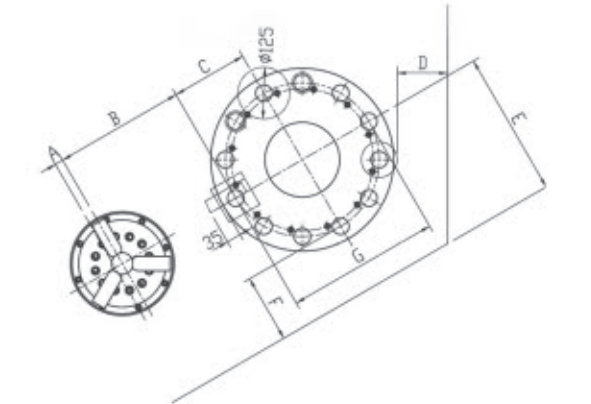

## Machine Measurement

mm / inch

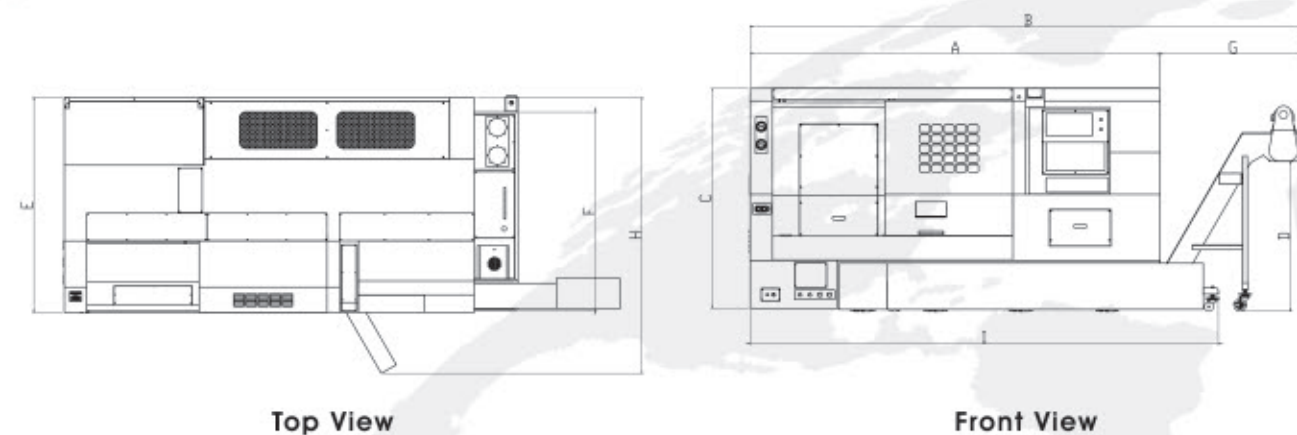

	A	B	C	D	E	F	G	H	I
GT12	1800 / 70.9	2758 / 108.4	1772 / 69.8	888 / 34.9	1540 / 60.6	1100 / 43.3	958 / 37.6	-	1875 / 73.9
SL15/SL20	1770 / 69.6	2725.5 / 107.1	1775 / 69.8	860 / 33.8	1335 / 52.5	1200 / 47.2	955.5 / 37.6	-	2095 / 82.3
SL25(MC)	2450 / 96.4	3540 / 139.1	1720 / 67.7	1245 / 48.9	1500 / 59	-	1090 / 42.8	1880 / 74	2603 / 102.5
SL30(MC)	2930 / 115.3	4277 / 168	1810 / 71.2	1236 / 48.6	1745 / 68.7	1693 / 66.5	1346 / 52.9	2228 / 87.6	3390 / 133.2
SL30L(MC)	3330 / 131.1	4676 / 183.8	1810 / 71.2	1236 / 48.6	1745 / 68.7	1693 / 66.5	1346 / 52.9	2228 / 87.6	3730 / 146.6
SL35(MC)	3050 / 120	4472 / 175.7	1910 / 75.2	1269 / 49.9	1940 / 76.2	1700 / 66.9	1422 / 55.9	2433.7 / 95.6	3665 / 144
SL35L(MC)	3450 / 135.8	4879 / 191.7	1920 / 75.5	1269 / 49.9	1940 / 76.2	1700 / 66.9	1429 / 56.2	2448 / 96.2	4063 / 159.7
SL40(MC)	3900 / 161.4	5320 / 209.4	1920 / 75.5	1250 / 49.1	2230 / 87.6	1770 / 69.6	1220 / 48	2745 / 108	4276.7 / 168
SL40L(MC)	4520 / 183.9	6039 / 237.3	1995 / 78.5	1254 / 49.3	2230 / 87.6	1770 / 69.6	1252 / 49.2	2745 / 108	5000 / 196.5



# Specification

	Performa SL 2-Axis Turning						Performa SL 2-Axis Turning			Performa Mill-Turn				Sub Spindle	
	GT12	SL15	SL20	SL25	SL30	SL35	SL40	SL25MC	SL30MC	SL35MC	SL40MC	SL30SMC			
					SL30L	SL35L	SL40L		SL30LMC	SL35LMC	SL40LMC				
CONTROL SYSTEM	AKIRA M <sub>z</sub> 845 (Fanuc G code compatible)						AKIRA M <sub>z</sub> 845 (Fanuc G code compatible)								
APPLICATION	X+Z						X+Z			X+Z+C				X+Z+B+C	
CAPACITIES															
Max. Swing Over Bed & Front Cover	mm/inch	400 / 15.7	450 / 17.7	450 / 17.7	530 / 20.9	600 / 23.6	650 / 25.6	750 / 29.5	530 / 20.9	600 / 23.6	650 / 25.6	750 / 29.5	600 / 23.6		
Max. Over Cross Slide	mm/inch	-	290 / 11.4	290 / 11.4	350 / 13.8	400 / 15.7	450 / 17.7	550 / 21.7	350 / 13.8	400 / 15.7	450 / 17.7	550 / 21.7	400 / 15.7		
Max. Cutting Diameter	mm/inch	-	290 / 11.4	290 / 11.4	350 / 13.8	400 / 15.7	450 / 17.7	550 / 21.7	280 / 11	330 / 13	360 / 14.2	550 / 21.7	400 / 15.7		
Max. Cutting Length	mm/inch	200 / 7.9	200 / 7.9	330 / 13	400 / 15.7	600 / 23.6 1000 / 39.4	600 / 23.6 1000 / 39.4	950 / 37.4 1500 / 59	380 / 15	540 / 21.26 940 / 37	540 / 21.26 940 / 37	830 / 32.7 1380 / 54.3	750 / 29.5		
Chuck Size	inch	Collet CR42 / 5C	Collet CR42 / 5C	6"	8"	8" STD 10" OPT	10" STD 12" OPT	15" STD 18" OPT	8"	8" STD 10" OPT	10" STD 12" OPT	15" STD 18" OPT	8" STD 10" OPT	6" STD	
Draw Tube Bore	mm/inch	42 / 1.7	42 / 1.7	45 / 1.8	52 / 2	65 / 2.6	78 / 3.1	103 / 4.1	52 / 2	65 / 2.6	78 / 3.1	103 / 4.1	65 / 2.6	31 / 1.2	
SPINDLE															
Max.Speed	rpm	6000	6000	6000	5000	4500	3500	2500	5000	4500	3500	2500	4500	6000	
Spindle Motor Output (Peak)	HP	17	24	24	17	24	30	60	17	24	30	60	24	24	
Spindle Torque (Peak)	N-m	84	137	137	202	305	727	2944 (gear box)	202	305	727	2944 (gear box)	305	124	
Spindle Nose	-	A2-5	A2-5	A2-5	A2-6	A2-6	A2-8	A2-11	A2-6	A2-6	A2-8	A2-11	A2-6	A2-5	
TRAVELS / FEEDRATES															
X Axis Travels	mm/inch	400 / 15.7	150+15 / 5.9+0.59	150+15 / 5.9+0.59	195+15 / 7.7+0.5	220+20 / 8.6+0.8	235+20 / 9.2+0.8	285+25 / 11.2+1	195+5 / 7.6+0.2	220+5 / 8.6+0.2	235+5 / 9.2+0.2	285+25 / 11.2+1	220+20 / 8.6+0.8		
Z Axis Travels	mm/inch	220 / 8.7	220 / 8.7	350 / 13.8	435 / 17.1	610 / 24 1010 / 39.8	630 / 24.8 1025 / 40.4	975 / 38.4 1520 / 58.9	435 / 17.1	600 / 23.6 1000 / 39.4	600 / 23.6 1000 / 39.4	900 / 35.4 1450 / 57.1	850 / 33.5		
Rapid Feed X/Z	m/min ipm	36 / 1417	36 / 1417	36 / 1417	36 / 1417	36 / 1417	36 / 1417	30 / 1181 36 / 1417	36 / 1417	36 / 1417	36 / 1417	30 / 1181 36 / 1417	36 / 1417		
Cutting Feed X/Z	m/min ipm	10 / 394	10 / 394	10 / 394	10 / 394	10 / 394	10 / 394	10 / 394	10 / 394	10 / 394	10 / 394	10 / 394	10 / 394		
TURRET															
Number of Tools	station	Gang Tool, 8	10	10	12	12	12	12	12	12	12	12	12		
O.D Tool Size	mm/inch	20 / 0.79	20 / 0.79	20 / 0.79	20 / 0.79	25 / 0.98	25 / 0.98	32 / 1.26	VDI30	VDI40	VDI40	BMT65	BMT65		
Boring Bar Shank	mm/inch	16 / 0.63	25 / 0.98	25 / 0.98	32 / 1.26	40 / 1.57	40 / 1.57	50 / 1.97	ER25	ER32	ER32	ER40	ER32		
Motor of Power Turret	kw/HP	-	-	-	-	-	-	-	3.7 / 5.5	3.5 / 5.5	3.5 / 5.5	5.5 / 7	3.5		
Max. Speed of Power Tooling	rpm	-	-	-	-	-	-	-	5000	4000	4000	4000	4000		
Tool Exchange (Neighbor Tool)	sec.	-	0.5	0.5	0.35	0.35	0.35	0.5	0.52	0.52	0.52	0.57	0.57		
TAILSTOCK															
Quill Travel	mm/inch	-	-	80 / 3.1	100 / 3.9 (OPT)	100 / 3.9	100 / 3.9	100 / 3.9	100 (OPT)	100 / 3.9	100 / 3.9	100 / 3.9	-		
Tailstock Travel	mm/inch	-	-	210 / 8.3	410 / 16.1 (OPT)	610 / 24 1010 / 31.7	630 / 24.8 1025 / 40.3	975 / 38.4 1550 / 61	410 / 16.1 (OPT)	570 970	570 970	900 / 35.4 1450 / 57.1	-		
Quill Taper	-	-	-	MT3	MT4 (OPT)	MT4	MT4	MT5	MT4 (OPT)	MT4	MT4	MT5	-		
ACCURACY															
Positioning	mm/inch	0.01 / 0.0039	0.01 / 0.0039	0.01 / 0.0039	0.01 / 0.0039	0.01 / 0.0039	0.01 / 0.0039	0.01 / 0.0039	0.01 / 0.0039	0.01 / 0.0039	0.01 / 0.0039	0.01 / 0.0039	0.01 / 0.0039		
Repeatability	mm/inch	0.006 / 0.00024	0.006 / 0.00024	0.006 / 0.00024	0.006 / 0.00024	0.006 / 0.00024	0.006 / 0.00024	0.006 / 0.00024	0.006 / 0.00024	0.006 / 0.00024	0.006 / 0.00024	0.006 / 0.00024	0.006 / 0.00024		
GENERAL															
Tank Capacity	Liters/gal	120 / 32	120 / 32	120 / 32	160 / 42	240 / 52.8	270 / 59.4	280 / 61.6	160 / 42	240 / 52.8	270 / 59.4	280 / 61.6	360 / 79.2		
Chip Disposal	-	Drawer STD Conveyor OPT	Drawer STD Conveyor OPT	Drawer STD Conveyor OPT	Drawer STD Conveyor OPT	Drawer STD Conveyor OPT	Drawer STD Conveyor OPT	Drawer STD Conveyor OPT	Drawer STD Conveyor OPT	Drawer STD Conveyor OPT	Drawer STD Conveyor OPT	Drawer STD Conveyor OPT	Drawer STD Conveyor OPT		
Power Requirement	KVA	18	20	22	25	28	30	35	30	30	30	35	45		
Floor Space (W x L)	mm <sup>2</sup> / inch <sup>2</sup>	1800 x 1580 / 70.8 x 62.2	1170 x 1338 / 69.7 x 53	1170 x 1338 / 69.7 x 53	2450 x 1500 / 97 x 59	2930 x 1745 / 115.3 x 69 3330 x 1745 / 131.1 x 69	3050 x 1844 / 120 x 73 3450 x 1844 / 135.8 x 73	3900 x 2165 / 154 x 85 4525 x 2165 / 178 x 85	2450 x 1500 / 97 x 59	2930 x 1745 / 115.3 x 69 3330 x 1745 / 131.1 x 69	3050 x 1844 / 120 x 73 3450 x 1844 / 135.8 x 73	3050 x 2165 / 153.5 x 85 3450 x 2165 / 177.9 x 85	3630 x 1910 143 x 75.2		
Weight	kgs/lb	2300 / 5071	2500 / 5512	2600 / 5732	4000 / 8378	5600 / 10582 6500 / 14330	5600 / 12346 6500 / 14330	6700 / 19842 7700 / 16975	4000 / 8378	5600 / 11023	5800 / 12787	6700 / 19842	7000 / 15432		